AR

TE

LIN

EA

PL

US

Un linguaggio diverso
è una diversa visione della vita.

A different language
is a different vision of life.

FEDERICO FELLINI

ARTELINEA

FIRENZE 1962

1

INCANTO

4

2

KIMONO

20

3

ATOLLO

30

4

MONOLITEPIÙ

44

5

DECOR

58

6

BOLLA
62

7

FRAME
78

8

REGOLO
92

9

DOMINO LEGNO
104

10

ZEN
114

11

MIRRORS
120

DESIGN Anita Brotto

1
—
IN
CAN
TO
—



Il vetro come filosofia.
L'eleganza come missione.

Class as a philosophy.
Elegance as a mission.

COMPOSITION
AL535

INCANTO
TOP & BASINTOP
OPALITE BIANCO 20

CABINET COVERING
FRASSINO "COTONE"

MIRROR
INCANTO COLLECTION







La parte e il tutto,
i particolari e il
progetto, sapienza
tecnica addolcita
dalla poesia.

The element and
the whole, the
details and the
project, the technical
expertise softened
by the poetry.





COMPOSITION

AL536

INCANTO

TOP & BASINTOP

OPALITE BIANCO 20

CABINET COVERING

FRASSINO "COTONE" +
CRISTALLO DECORATO

MIRROR

INCANTO COLLECTION









COMPOSITION

AL537

INCANTO

TOP & BASINTOP

AVANA 45

CABINET COVERING

FRASSINO "CANAPA" +
AVANA SILK 05

MIRROR

INCANTO COLLECTION





NOCE CANALETTO

FRASSINO "COTONE"

FRASSINO "CHINA"

FRASSINO "CANAPA"



Less is more
ovvero piccoli gesti
per uno scrigno.

Less is more
creating small
gestures for
a treasure chest.



COMPOSITION

AL537 B

INCANTO

TOP & BASINTOP

OPALITE BIANCO 20

CABINET COVERING

NOCE CANALETTO + NOCE 41

MIRROR

INCANTO COLLECTION





DESIGN Anita Brotto

2

KIM

O

NO



Cura dei dettagli, qualità dei materiali, valore delle finiture, design oltre le mode.

The study of detail, versatility and high quality materials, the benefit of the handles, design beyond fashion.

COMPOSITION

AL538

KIMONO

TOP & BASINTOP

SEPPIA 60

CABINET COVERING

SEPPIA 60

MIRROR

LASER COLLECTION





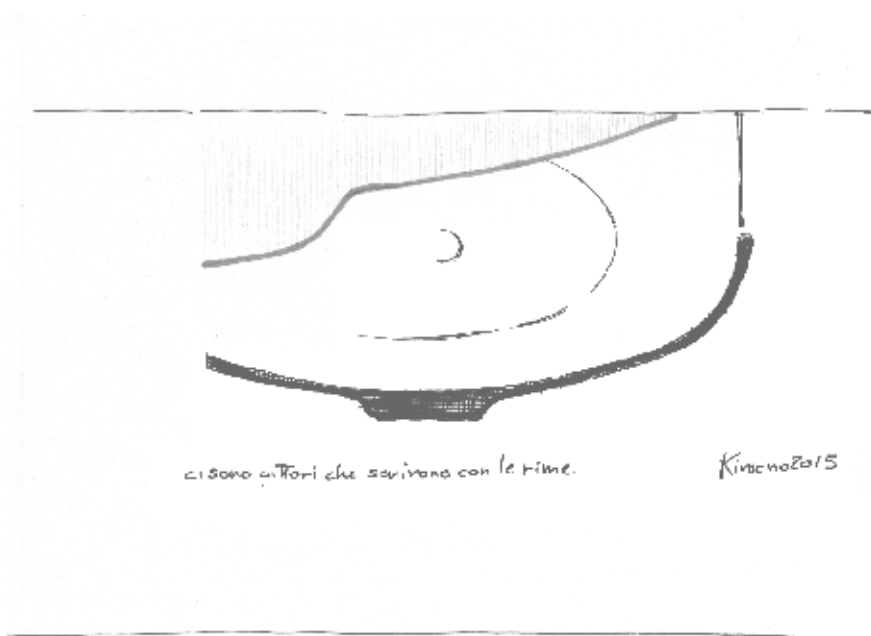

La forma “a tutto tondo” del vetro plasmato è chiave di lettura di Kimono.

The “All Round” form of shaped glass with a unique, personal curve is the right interpretation of Kimono.







COMPOSITION
AL539

KIMONO
TOP & BASINTOP
OPALITE BIANCO 20

CABINET COVERING
BIANCO ASSOLUTO 30

MIRROR
INCANTO COLLECTION







3

DESIGN Anita Brotto



A

T O

L L

O





Il disegno razionale e rigoroso si ammorbidisce nella materia plasmata.

The functional and rigorous design becomes softer due to the use of shaped materials.







COMPOSITION
AL540

ATOLLO
TOP & BASINTOP
OPALITE BIANCO 20

CABINET COVERING
WENGÉ + BIANCO

MIRROR
ATOLLO COLLECTION





COMPOSITION

AL540B

ATOLLO

TOP & BASINTOP

OPALITE BIANCO 20

CABINET COVERING

BIANCO

MIRROR

ATOLLO COLLECTION



COMPOSITION
AL541
ATOLLO + VERO
TOP & BASINTOP
OPALITE BIANCO 20
CABINET COVERING
BIANCO
MIRROR
ATOLLO COLLECTION







La tradizione del
lavabo a mensola
riscritta in Opalite.

The traditional
basin shelf, renamed
in Opalite.



COMPOSITION
AL542

ATOLLO
TOP & BASINTOP
OPALITE BIANCO 20

CABINET COVERING
WENGÈ

MIRROR
ATOLLO COLLECTION



COMPOSITION

AL543

ATOLLO

TOP & BASINTOP

OPALITE BIANCO 20

CABINET COVERING

WENGÉ

MIRROR

ATOLLO COLLECTION





6

8

12

1

4



MO

NO

LI

TE

PIU



L'essenzialità del design
sposa il decoro.

Essential design enriched by
elegant patterns.





COMPOSITION
AL544

MONOLITEPIÙ
TOP & BASINTOP
OPALITE BIANCO 20

CABINET COVERING
"TIPOGRAFICO" BIANCO
ASSOLUTO 30 / SEPPIA 60

MIRROR
LASER COLLECTION





COMPOSITION

AL545

MONOLITEPIÙ

TOP & BASINTOP

OPALITE BIANCO 20

CABINET COVERING

"PAPAVERO"

BIANCO ASSOLUTO 30 / SEPIA 60

MIRROR

LASER COLLECTION

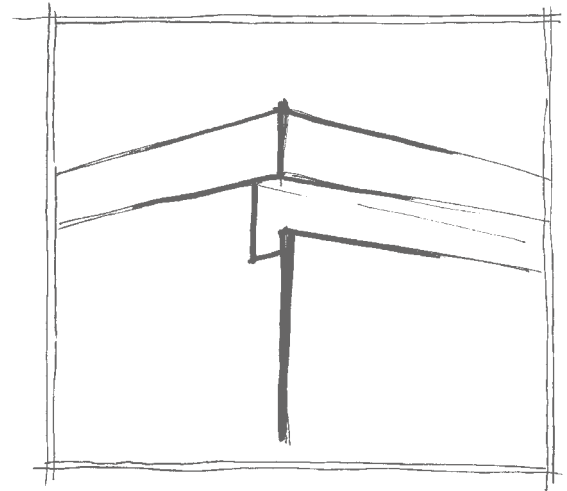

COMPOSITION

AL545B

MONOLITEPIÙ

TOP & BASINTOP

OPALITE BIANCO 20

CABINET COVERING

"TIPOGRAFICO"

SEPPIA 60 / SPECCHIO

MIRROR

LASER COLLECTION





COMPOSITION
AL546
MONOLITEPIÙ
TOP & BASINTOP
OPALITE BIANCO 20
CABINET COVERING
"PAPAVERO"
SEPPIA 60 / SPECCHIO
MIRROR
LASER COLLECTION







COMPOSITION
AL547

MONOLITEPIÙ
TOP & BASINTOP
OPALITE BIANCO

20 CABINET COVERING
"PAPAVERO"
SEPPIA 60 / SPECCHIO

MIRROR
LASER COLLECTION





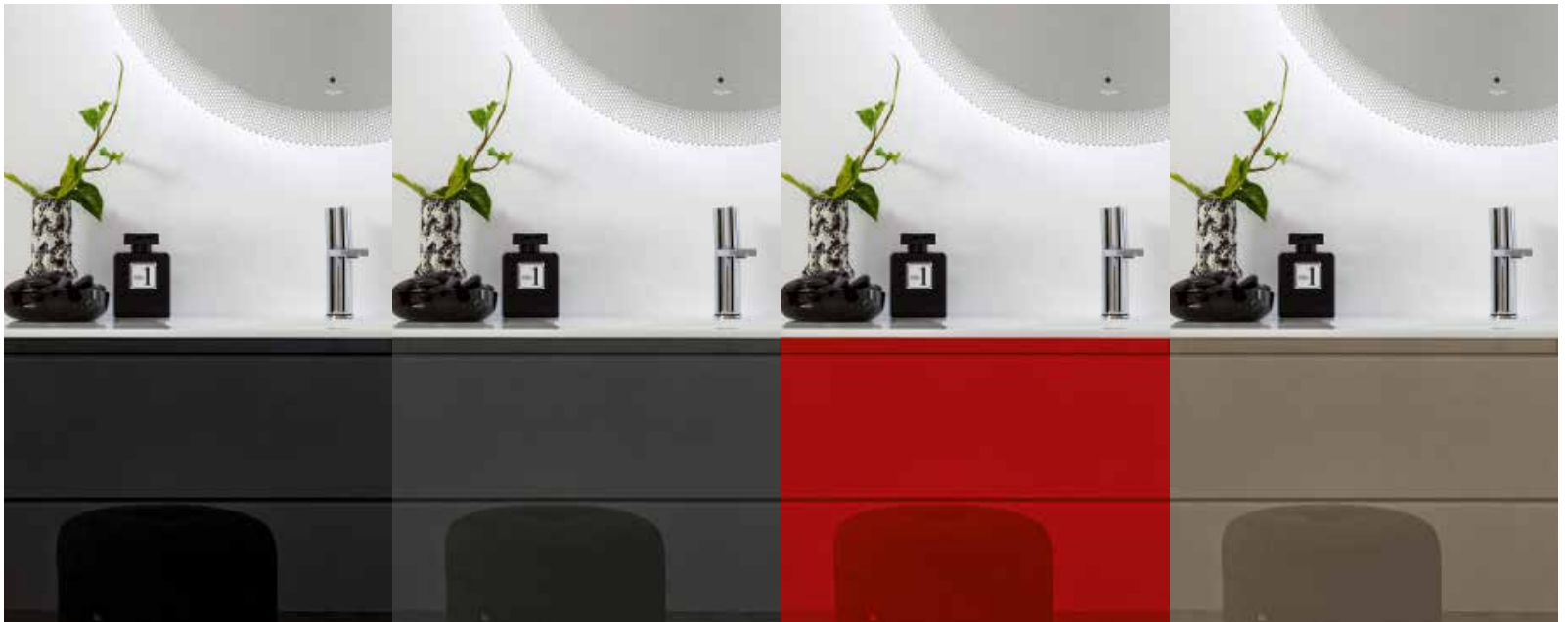

SEPIA 60

FUMO 11

MELOGRANO 23

AVANA 45

MonolitePiù: nuove finiture, nuovi decori,
nuova tecnologia.

MonolitePiù: new finishes, new patterns,
new technology

DESIGN Anita Brotto

5



DE
COR





Oggetto prezioso, ricco, personalizzabile
e sempre elegante.

A precious object, rich, customized and
always elegant.

COMPOSITION

AL332B

DECOR

TOP & BASINTOP

OPALITE NERO 24

CABINET COVERING

SEPPIA 60

MIRROR

LED COLLECTION

FLOORING COVERING

OPALITE 20 +

OPALITE NERO 24





DESIGN Anita Brotto

6



BO

LL

A





*Gioco delle trasparenze e
della leggerezza.*

*Transparency and lightness
effects.*





COMPOSITION
AL548

BOLLA + INFRA
TOP & BASINTOP
OPALITE BIANCO 20

CABINET COVERING
BIANCO ASSOLUTO 30

MIRROR
OBLÒ COLLECTION





COMPOSITION
AL549

BOLLA
TOP & BASINTOP
OPALITE BIANCO 20

CABINET COVERING
BIANCO ASSOLUTO 30

MIRROR
BROADWAY COLLECTION





Il vetro nella
sua massima
espressione:
forma e trasparenza.

Glass in its highest
expression: shape
and transparency.





COMPOSITION
AL550B
BOLLA
TOP & BASINTOP
OPALITE BIANCO 20
MIRROR
BOX COLLECTION

COMPOSITION
AL550
BOLLA
TOP & BASINTOP
OPALITE BIANCO 20
MIRROR
LASER COLLECTION





COMPOSITION

AL551

BOLLA

TOP & BASINTOP

OPALITE BIANCO 20

MIRROR

BARCODE COLLECTION







I complementi arricchiscono e completano i programmi Artelinea.

The complements enrich and complete the programs available from Artelinea.

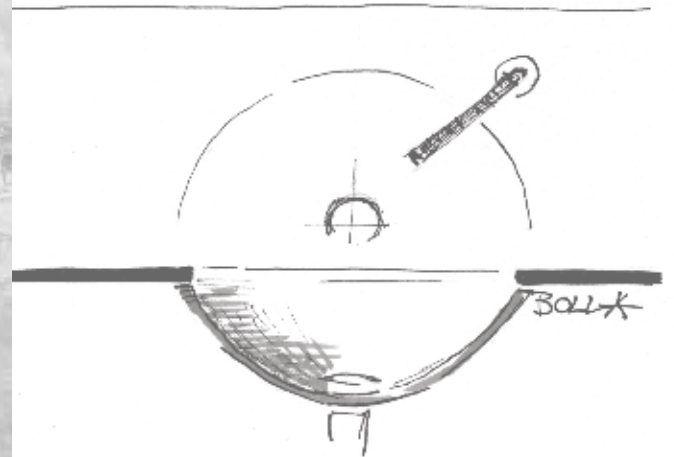



DESIGN Tommaso Nani
Noa Ikeuchi

7



FRA

ME

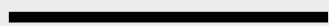



*Il gesto calibrato si traduce in eleganza.
The calibrated gesture becomes elegance.*





COMPOSITION

AL552

FRAME

TOP & BASINTOP

OPALITE BIANCO 20

CABINET COVERING

SEPPIA 60

MIRROR

LUMINEE COLLECTION

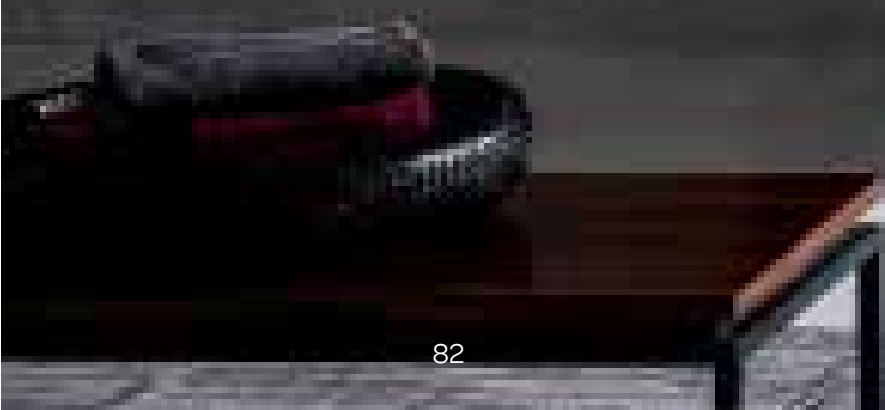
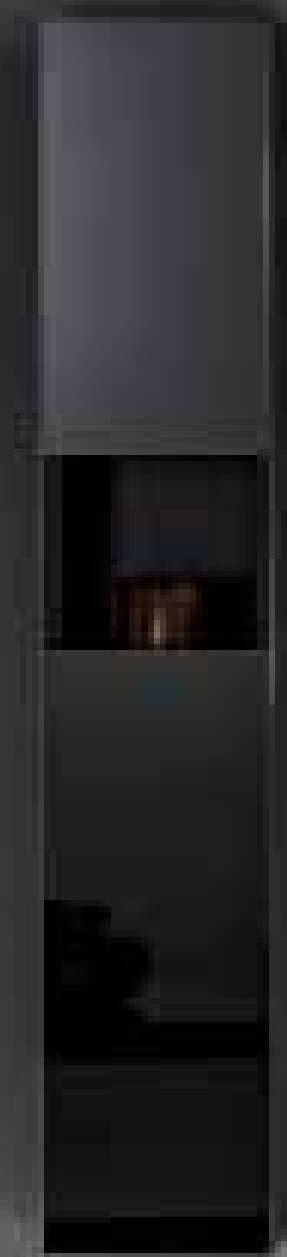



COMPOSITION
AL553

FRAME
TOP & BASINTOP
OPALITE NERO 24

MIRROR
BOX COLLECTION





I dettagli curati descrivono la passione per il prodotto, la ricerca del bello.

The well-finished details describe the passion of the product and the search for beauty.

Specchi e
illuminazione:
Artelinea
caratterizza
l'ambiente.

Mirrors
and lighting:
Artelinea
enriching the
environment.

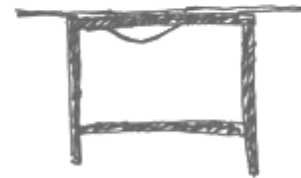
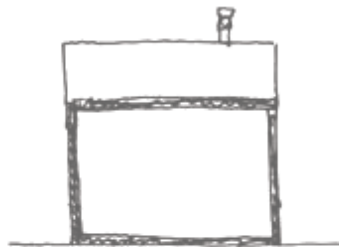
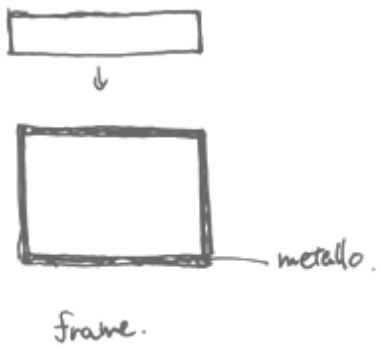



COMPOSITION

AL554

FRAME

TOP & BASINTOP

OPALITE BIANCO 20

CABINET COVERING

SEPPIA 60

MIRROR

MOVE COLLECTION





Con accessori che disegnano lo spazio,
Frame diventa programma completo.

With accessories that draw the space,
Frame becomes a complete plan.





8



RE
GO
LO





Libertà espressiva e progettuale coniugata
ad un disegno elegante, di carattere, prezioso.

Freedom in design and planning joined by
the use of elegant and precious materials, thus
creating a product with great character.

COMPOSITION

AL555

REGOLO

TOP & BASINTOP

OPALITE BIANCO 20

CABINET COVERING

BIANCO ASSOLUTO 30

MIRROR

LASER COLLECTION







Nuovo concept,
nuove funzioni,
nuovi dettagli.

New concept,
new functionality,
new details.





COMPOSITION

AL556

REGOLO

TOP & BASINTOP

OPALITE BIANCO 20

CABINET COVERING

BIANCO ASSOLUTO 30

MIRROR

LED COLLECTION



Opalite bianca e nera by Artelina: un materiale per il design.

Opalite bianca and nero by Artelina: a material from and to design.

COMPOSITION
AL557

REGOLO + FRAMMENTO
TOP & BASINTOP
OPALITE NERO 24

CABINET COVERING
SEPPIA 60

MIRROR
FLASH COLLECTION

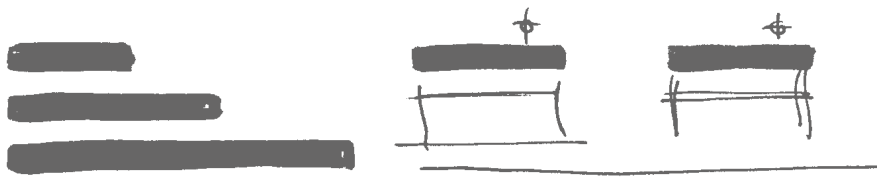



COMPOSITION

AL558

REGOLO + VERO

TOP & BASINTOP

OPALITE NERO 24

CABINET COVERING

BIANCO ASSOLUTO 30

MIRROR

LASER COLLECTION





9

DESIGN Anita Brotto

DO

MI

NO

LEG

NO



*Il Monoblocco versatile sposa il legno.
The versatile vanity unit that embraces wood.*



COMPOSITION
AL559

DOMINO LEGNO
TOP & BASINTOP
OPALITE BIANCO 20

CABINET COVERING
NATURAL +
BIANCO ASSOLUTO 30

MIRROR
LED COLLECTION





Nuove essenze arricchiscono il programma Domino.

New materials enrich the Domino style.









COMPOSITION
AL560

DOMINOLEGNO
TOP & BASINTOP
OPALITE BIANCO 20

CABINET COVERING
NATURAL

MIRROR
LED COLLECTION





10



Z E

N

Nella semplicità del disegno la risposta
alle richieste più “estreme”.

In the design simplicity the answer
to the request more “extreme”





COMPOSITION
AL561

ZEN
TOP & BASINTOP
OPALITE BIANCO 20

CABINET COVERING
SEPPIA,60

MIRROR
ZEN COLLECTION



Compatto e versatile
Zen è il "piccolo"
di casa Artelinea.

Versatile and
compact Zen is the
"little" of Artelinea
Home.

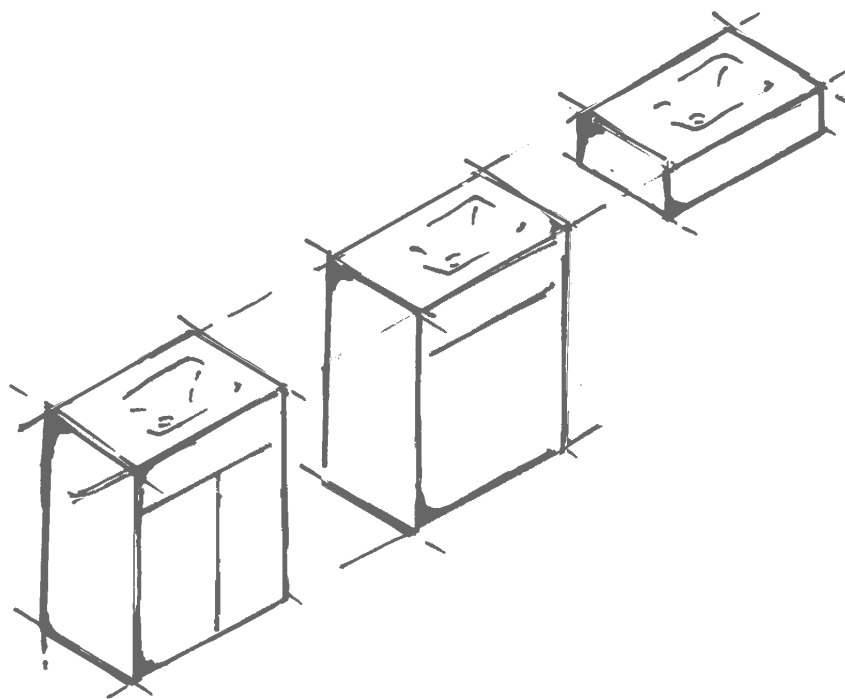

COMPOSITION
AL562

**ZEN TOP
& BASINTOP**
OPALITE BIANCO 20

CABINET COVERING
ROSSO SILK 92

MIRROR
ZEN COLLECTION





11
MIRROR
LESS



Gli specchi Artelinea raccontano la passione,
la storia, la tecnologia.

The mirrors from Artelinea explain the
passion, the story and the technology





“Dicono che Efesto fece uno specchio per Dioniso e che il dio, guardandovi dentro e contemplando la propria immagine, si gettò a creare tutta l’umanità”.

“They say that Hephaestus made a mirror for Dionysus and, seeing him in and contemplating his own image, he decided to create the whole of humanity”.

PROCLO



0248
●●●●





22 ROSSO
92 ROSSO SILK
23 MELOGRANO
64 MELOGRANO SILK
29 CAROTA
65 CAROTA SILK

22 LIMONE
66 LIMONE SILK
41 NOCE
67 NOCE SILK
16 TERRA
94 TERRA SILK

43 MOKA
76 MOKA SILK
45 AVANA
05 AVANA SILK
33 TORTORA
53 TORTORA SILK

49 SABBIA
79 SABBIA SILK
30 BIANCO ASSOLUTO
70 BIANCO SILK
60 SEPIA
93 SEPIA SILK

11 FUMO
47 FUMO SILK
54 GRIGIO
07 GRIGIO SILK
50 ARGENTO
83 ARGENTO SILK

39 NOTTE
99 NOTTE SILK
62 OCEANO
00 OCEANO SILK
26 SARDINIA
59 SARDINIA SILK

63 ERBA
44 ERBA SILK
15 GLICINE
89 GLICINE SILK
35 CIPRIA
86 CIPRIA SILK

Artelinea coniuga la
tradizione del vetro
con la freschezza dei
nuovi colori.

Artelinea mingles
the tradition of glass
with new colours to
create a freshness in
design.

“I colori sono azioni della luce, azioni
e passioni”.

“Colours are the creation of light
and passion”.

JOHANN WOLFGANG GOETHE

design **anita brotto**
photo & stylist **link**
printing **grafiche antiga spa**

Copyright © 2015 ARTELINEA SpA

ARTELINEA SpA si riserva il diritto di variare, senza alcun preavviso, quanto descritto e fotografato in questo catalogo.

Tutti i diritti riservati.

Questa pubblicazione, o parte di essa, non può essere riprodotta senza l'autorizzazione scritta di ARTELINEA SpA.

I pigmenti colorati, così come quelli neutri o trasparenti, reagiscono ai flash, variando l'aspetto cromatico; per questo motivo, gli oggetti pubblicati in questo catalogo, possono presentare lievi differenze cromatiche rispetto alla realtà.

ARTELINEA SpA reserves it self the right to vary, without any warning, the products described and photographed in this catalogue.

All rights reserved.

This publication, cannot be reproduced in any part, in any case without the written authorization of ARTELINEA SpA.

The coloured pigments, as well as the neutral and transparent ones, react to the photographic flash, thus varying their chromatic aspect. For this reason the tones of the objects shown in this catalogue may appear slightly different in reality.



ARTELINEA

FIRENZE 1962

ARTELINEA S.P.A.

Via Degli Innocenti, 2
50063 Figline e Incisa Valdarno
(FIRENZE) · Italy
T +39 055 961 961
F +39 055 96 22 380
www.artelinea.it
info@artelinea.it

Headquarters:

Via dell'Industria,1
Loc. Santa Barbara
52022 Cavriglia (AR)
GPS: N43°33'44" E 11°28'09"